

# Canal Compact

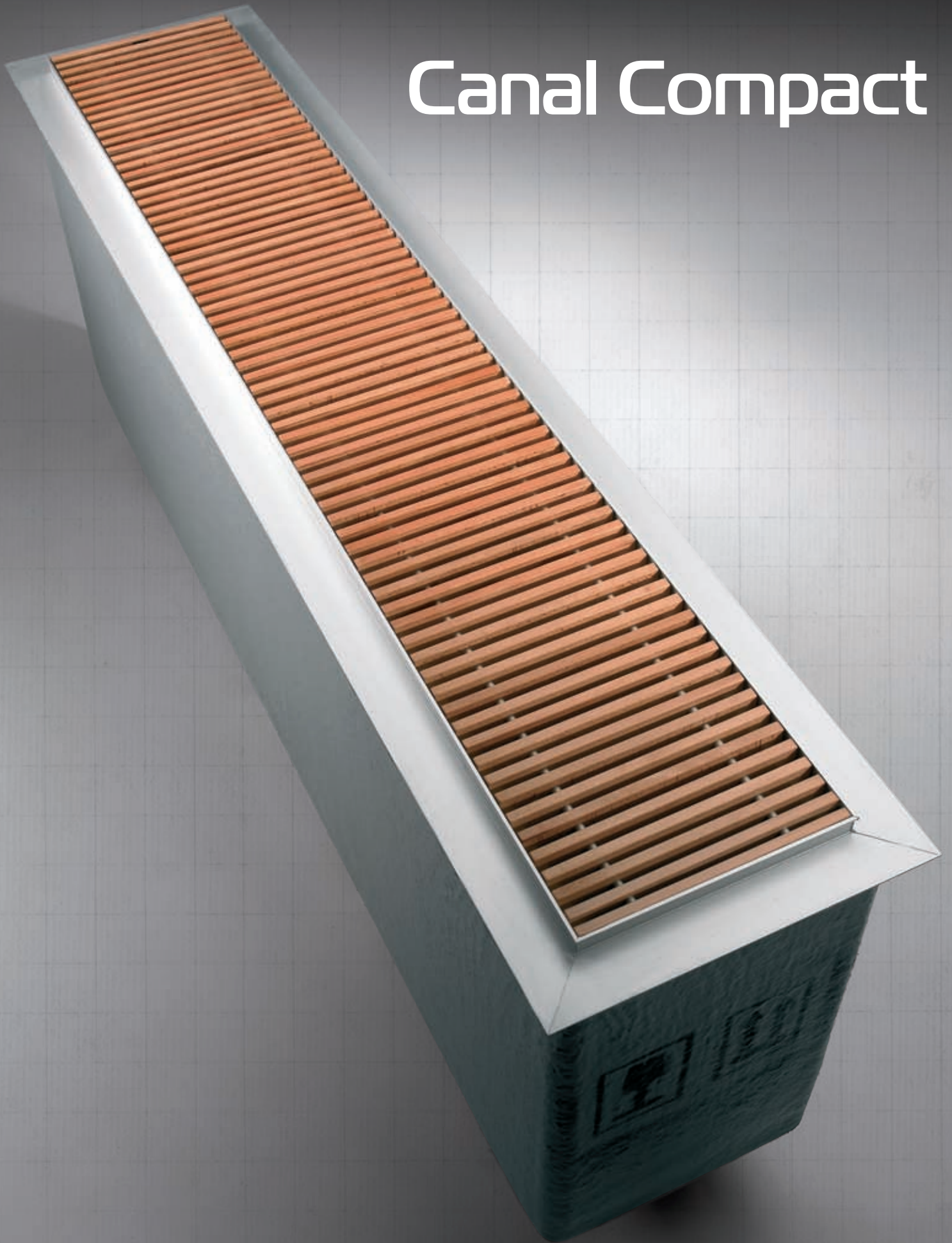

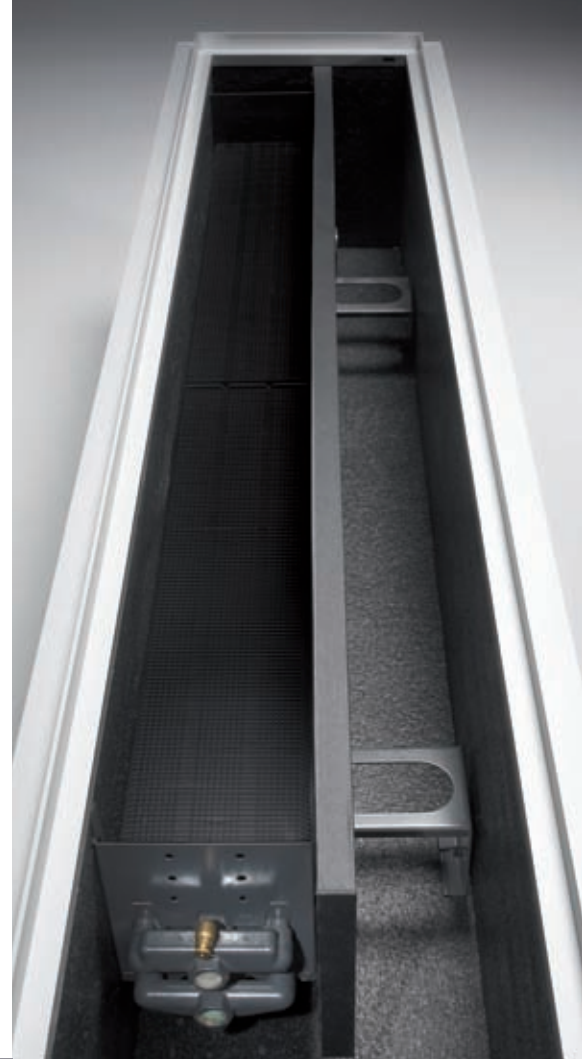
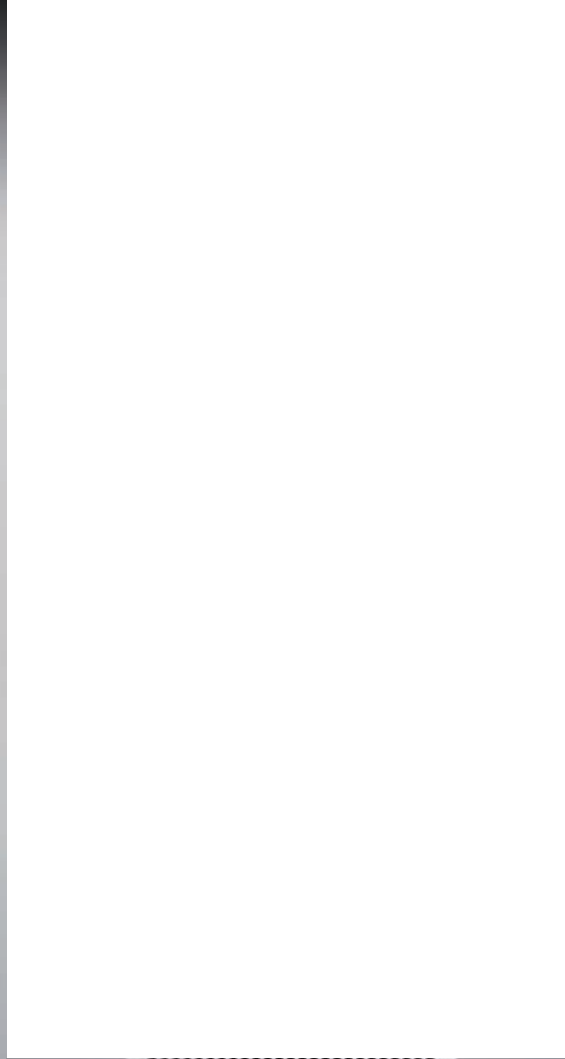

1. Complete Canal Plus underfloor unit
2. Heat exchanger and inside finish of the duct in dark grey
3. Enlarged range of grilles

## Canal Plus Operating principal

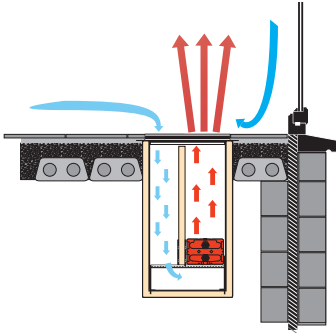

### Practical advice

Tests done by the Jaga Experience Lab and the Technical Department of the University of Eindhoven (The Netherlands) have proven that the most efficient heat output will be obtained when the heat exchanger is fitted on the window side of the duct. Ensure there is sufficient space between the duct and the window, as it is important that curtains do not hang over the duct. It is preferable that the heat exchanger covers the total length of the window.

## Options

### Flexible connection from stainless steel

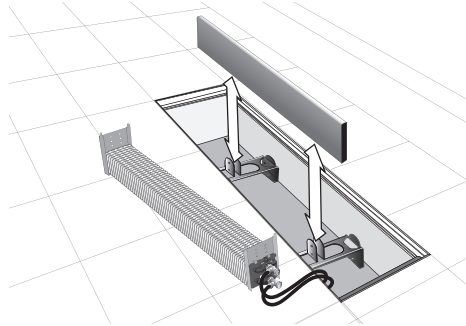

- makes the Low-H<sub>2</sub>O heat-exchanger detachable for maintenance after water-side connection.
- simple and fast assembly
- highest quality stainless steel
- length 60 cm (stretches to ± 1 m)
- 100% diffusion-proofed
- prevents squeezing shut in bends
- welded connection

#### CODE

CCFC.000060

Complete connection sets with or without flexible connections: see page 169.

### Cover strip

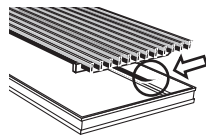

For aluminium and wood grilles. Black adhesive rubber strip, thickness 1 mm.

To hide the bottom edge of the frame and to avoid contact noises. Order the number of rolls required according to circumference of the frame: (width plus length) x 2.

#### CODE

7690.02 Roll 6 metre

### Extended air vent



For easy and rapid venting by Canal Plus and Canal Compact.

#### CODE

##### Canal Compact

5090.114078 R 1.5  
5090.114178 R 4.0

##### Canal Plus

	height separation wall
5090.114078	20 cm
5090.114178	30 cm
5090.114278	40 cm
5090.114378	50 cm

### Different length

See parts page 234/236.

Polyester ducts to 6 metres in one piece, metal ducts to 4 metres in one piece: unit can be put together from the parts list

### Different height and width

Price on request.

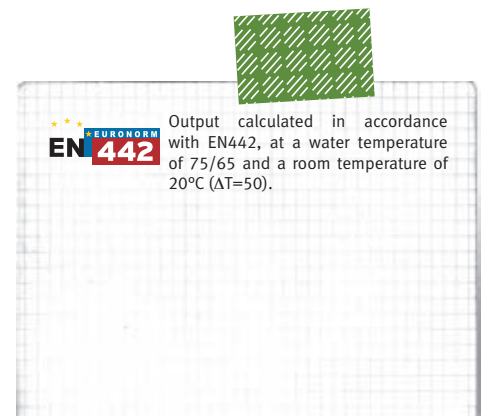

# Canal Plus\_Overview grilles

## Roll-up wooden grilles

Merbau natural **RMN**    Oak natural **RON**    Beech natural **RBN**  
 Roll-up Merbau Natural    Roll-up Oak Natural    Roll-up Beech Natural



Merbau varnished **RMV**    Oak varnished **ROV**    Beech varnished **RBV**  
 Roll-up Merbau Varnished    Roll-up Oak Varnished    Roll-up Beech Varnished



Roll-up natural or varnished grille, with dark brown coloured synthetic distance pieces. Frame in black anodized aluminium. Free air flow 63%.

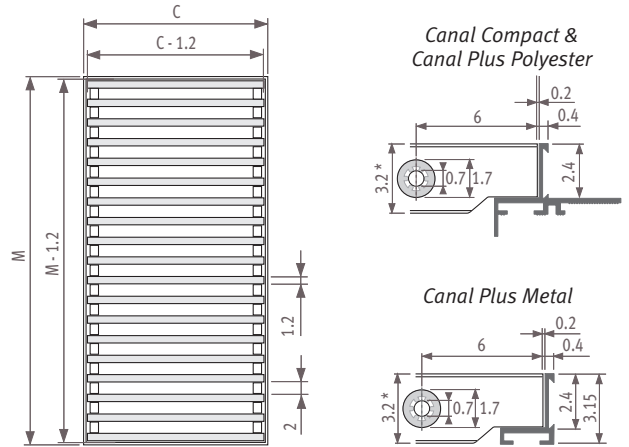

Dimensional tolerance width grille: +0/+0.2 cm

\* Up to and including width grille 40.8 cm: 2.4 cm  
 Beginning from width grille 44.8: 3.2 cm

## Designo roll-up wooden grilles

Merbau natural **DMN**    Oak natural **DON**    Beech natural **DBN**  
 Designo Merbau Natural    Designo Oak Natural    Designo Beech Natural



Merbau varnished **DMV**    Oak varnished **DOV**    Beech varnished **DBV**  
 Designo Merbau Varnished    Designo Oak Varnished    Designo Beech Varnished



Roll-up natural or varnished grille, Designo model with reduced slat spacing and natural colour anodized aluminium distance pieces. Frame in natural coloured anodized aluminium. Free air flow 52%.

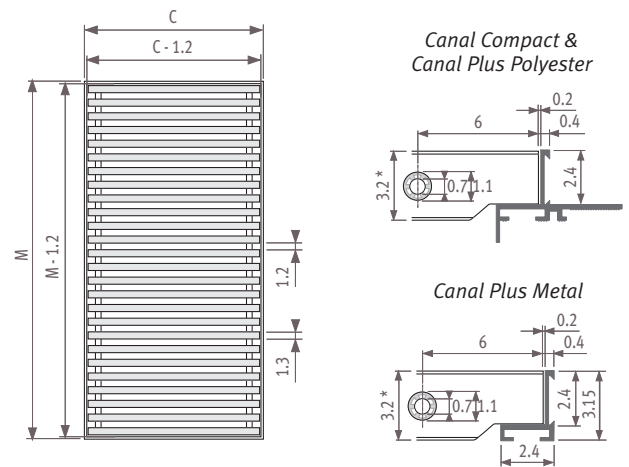

Dimensional tolerance width grille: +0/+0.2 cm

\* Up to and including width grille 40.8 cm: 2.4 cm  
 Beginning from width grille 44.8: 3.2 cm

# Canal Plus\_Overview grilles

## Roll-up aluminium grilles

Natural coloured **RNA** Black **RBL** Dark brown\* **RDB**  
 Roll-up Natural Roll-up Black Roll-up Dark Brown



Roll-up anodized aluminium grille with frame in the same colour. Free air flow 70%.

\* Canal Plus Polyester: dark brown grille with black frame.

Canal Plus Metal: dark brown grille and frame.

Free air flow 70%.

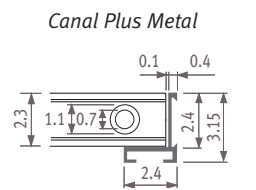
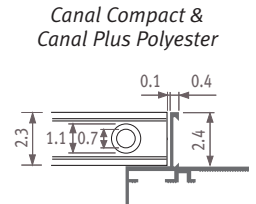
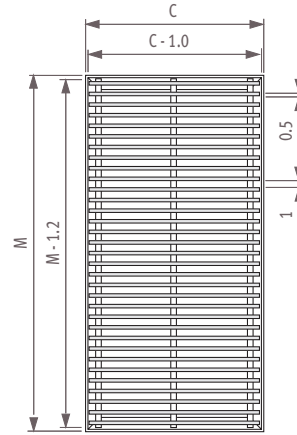

Dimensional tolerance width grille: +0/+0.2 cm

## Roll-up stainless steel grilles

Stainless steel **RSS**  
 Roll-up Stainless Steel



Roll-up grille in rustproof high-grade steel V2A1.4301. With matching frame in anodized aluminium in natural colour, including mounted black rubber strip to cover the bottom edge of the frame, and to avoid contact noises. Free air flow 60%.

Only available when ordered from parts: see page 231-235.

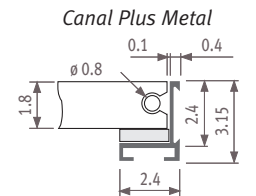
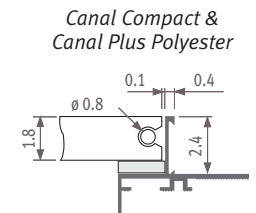
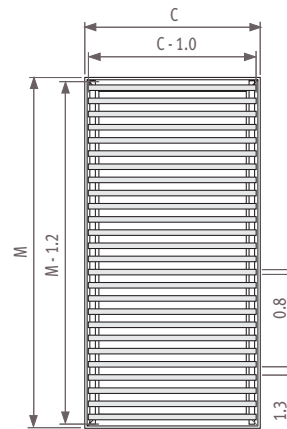

Dimensional tolerance width grille: +0/+0.2 cm



Canal Plus

## Canal Plus\_Overview grilles

### Rigid aluminium grilles

Natural coloured **SNA** Black **SBL** Dark brown\* **SDB**  
 Stiff **N**atural Stiff **B**lack Stiff **D**ark Brown



Rigid anodized aluminium grille with frame in the same colour. Free air flow 75%.

\* Canal Plus Polyester: dark brown grille with black frame.

Canal Plus Metal: dark brown grille and frame.

Free air flow 75%.

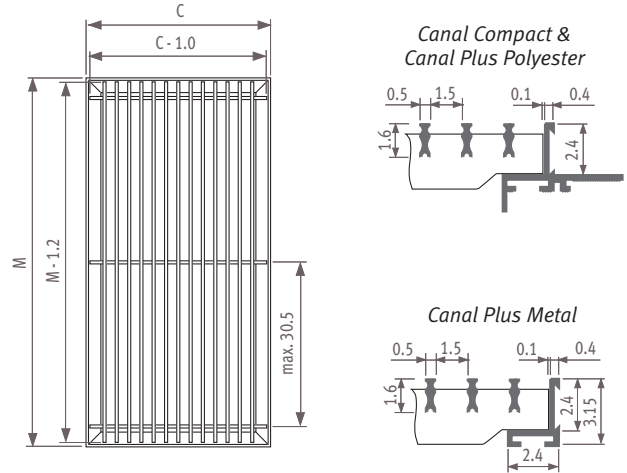

Dimensional tolerance width grille: +0/+0.2 cm

### Designo rigid aluminium grilles

Natural coloured **DNA** Black **DBL** Dark brown\* **ddb**  
 Designo **N**atural Designo **B**lack Designo **D**ark Brown



Rigid anodized aluminium grille, Designo model with reduced slat spacing. Frame in the same colour. Free air flow 62.5%.

\* Canal Plus Polyester: dark brown grille with black frame.

Canal Plus Metal: dark brown grille and frame.

Free air flow 62.5%.

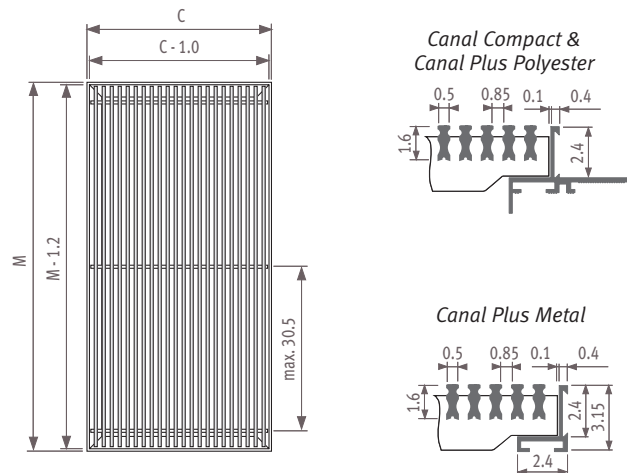

Dimensional tolerance width grille: +0/+0.2 cm

## Canal Plus\_Overview grilles

### Rigid aluminium grilles lacquered

Lacquered **COLOUR/SNC**  
Stiff stiff Natural Colour



32 colours

To ensure perfect adherence of the lacquer coating, the anodized aluminium is painted with an extremely wear-resistant and UV-resistant polyester lacquer coating of the highest quality. Grille and frame in the same colour, gloss degree 70%: see colour chart.  
Free air flow 75%

Attention: only the colour codes beginning with 4 and colour 006 are suitable (extra hard-wearing).

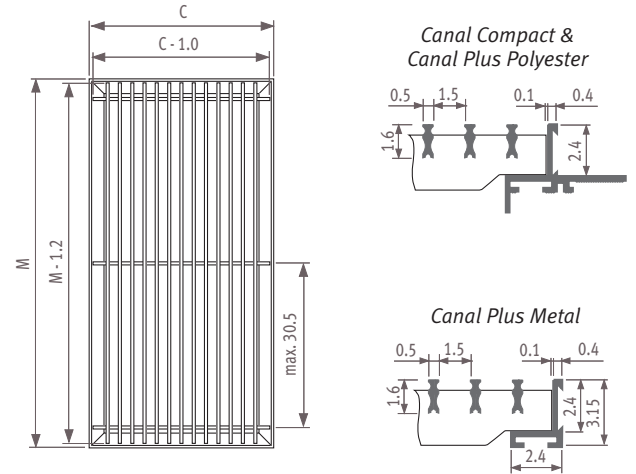

Dimensional tolerance width grille: +0/+0.2 cm

### Designo rigid aluminium grilles lacquered

Lacquered **COLOUR/DNC**  
Designo stiff Natural Colour



32 colours

To ensure perfect adherence of the lacquer coating, the anodized aluminium is painted with an extremely wear-resistant and UV-resistant polyester lacquer coating of the highest quality. Grille and frame in the same colour, gloss degree 70%: see colour chart.  
Free air flow 62.5%

Attention: only the colour codes beginning with 4 and colour 006 are suitable (extra hard-wearing).

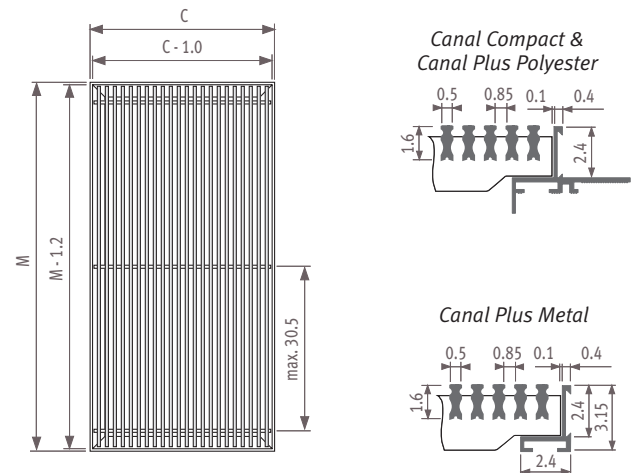

Dimensional tolerance width grille: +0/+0.2 cm



Canal Plus

## Canal Compact\_Composition

**LOW**  
**H<sub>2</sub>O** **30**  
YEARS GUARANTEE

### Grille

available in several design types and colours in anodized aluminium, several types of wood and stainless steel.

**Separation wall**  
black polyurethane plate, thickness 2.5 cm.

**Low-H<sub>2</sub>O heat exchanger**  
copper tubes and pure aluminium fins, with brass collectors for one or two pipe connection. Dark grey lacquered in RAL 7024.

**Feet**  
from electrolytic galvanized steel plate; thickness 1.5 mm. Dark grey lacquered in RAL 7024.

**Waterproof polyester duct**  
with integrated natural coloured or black anodized frame.

**R 1.5 / K 0.67**  
4 mm polyester  
25 mm polyurethane insulation  
5 mm polyethylene insulation

**R 4.0 / K 0.25**  
4 mm polyester  
80 mm polyurethane insulation  
5 mm polyethylene insulation

**Cover plate**  
fibreboard, 1.5 cm, with pre-assembled spacer sleeves (metre load max. 90 kg/m).

**Brackets**  
from electrolytic galvanized steel plate. Dark grey lacquered in RAL 7024.

**Air vent**  
(or mount an air vent on the central heating system).

**Building in-opening:**

height	H	+ 2 cm
length	L	
width	B	

### Attention!

In case of a high water table (+30 cm) the upward pressure can seriously damage the polyester duct (leakage) and the floor (uplift). For water tables higher than 30 cm we advise special ducts and the use of additional floor-anchors. Info: Jaga

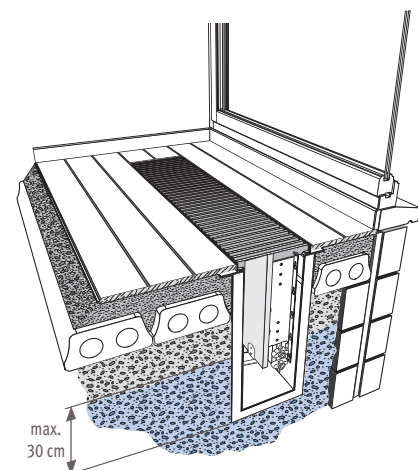

## Canal Compact\_Dimensions

### Canal Compact Polyester R 1.5

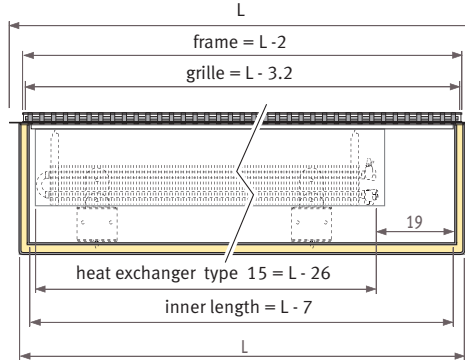
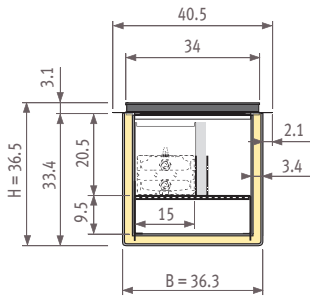

Heat exchanger type 15

R-value =  $1.5 \text{ m}^2\text{K}/\text{w}$   
K-value =  $0.67 \text{ w}/(\text{m}^2.\text{K})$

4 mm polyester  
25 mm polyurethane foam  
5 mm polyethylene foam

### Canal Compact Polyester R 4.0

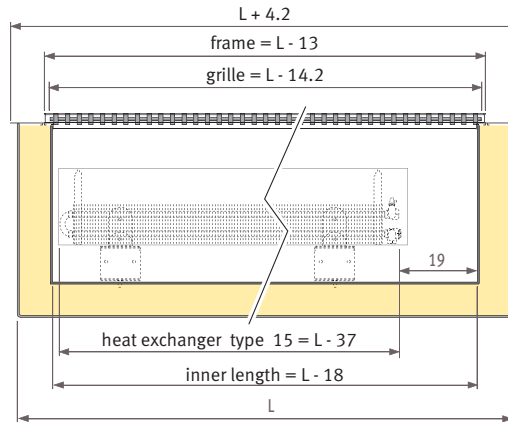
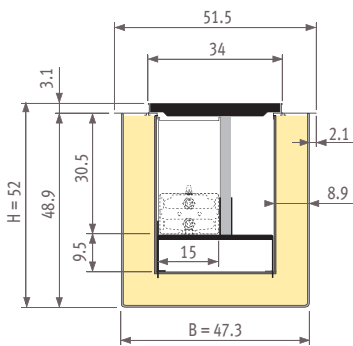

Heat exchanger type 15

R-value =  $4.0 \text{ m}^2\text{K}/\text{w}$   
K-value =  $0.25 \text{ w}/(\text{m}^2.\text{K})$

4 mm polyester  
80 mm polyurethane foam  
5 mm polyethylene foam



## Canal Compact R 1.5

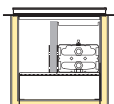
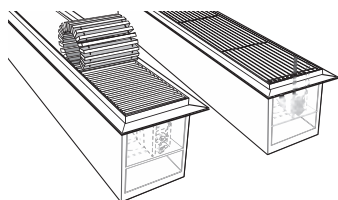

### Standard delivery

- waterproof polyester duct, fully pre-mounted, with integrated black anodized frame
- grille
- cover plate (meter load max. 90 kg).
- Low-H<sub>2</sub>O heat-exchanger, dark grey lacquered in RAL 7024
- feet and brackets, dark grey lacquered in RAL 7024
- black separation wall from polyurethane foam
- straight air vent 1/8"
- drain cock 1/2"

### Grille codes

#### Rigid grilles

SNA Aluminium natural coloured

#### Roll-up grilles

RMN Merbau natural

RON Oak natural

## Rigid grilles

### Aluminium natural coloured



ORDERING CODE: CC15. *code* 036 *height* 178 *length* 36 *width* /SNA *grille*

H	B	L heat exchanger	L 178	198	218	238	258
36	36	75/65/20	1817	2059	2301	2543	2786
		90/70/20	2329	2639	2950	3260	3571

Rigid grille in natural coloured anodized aluminium. Frame in black anodized aluminium. Free air flow 75%.

Deliverable with frame in natural coloured aluminium, or with other grilles (see page 230): for this put the unit together from parts.

Caution: extended delivery time!

## Roll-up grilles

### Merbau or oak\_natural



ORDERING CODE: CC15. *code* 036 *height* 178 *length* 36 *width* /RMN *grille* /RON

H	B	L heat exchanger	L 178	198	218	238	258
36	36	75/65/20	1762	1997	2232	2467	2702
		90/70/20	2259	2560	2861	3162	3464

Roll-up grille in merbau or oak natural, with dark brown coloured synthetic distance pieces. Frame in black anodized aluminium. Free air flow 63%.

## Canal Compact R 4.0

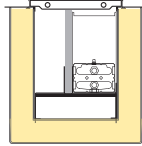
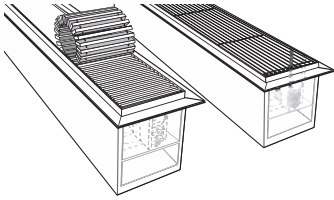

### Standard delivery

- waterproof polyester duct, fully pre-mounted, with integrated black anodized frame
- grille
- cover plate (meter load max. 90 kg).
- Low-H<sub>2</sub>O heat-exchanger, dark grey lacquered in RAL 7024
- feet and brackets, dark grey lacquered in RAL 7024
- black separation wall from polyurethane foam
- straight air vent 1/8"
- drain cock 1/2"

### Grille codes

#### Rigid grilles

SNA Aluminium natural coloured

#### Roll-up grilles

RMN Merbau natural

RON Oak natural

## Rigid grilles

### Aluminium natural coloured



ORDERING CODE: CC40. *code* *height* *length* *width* *grille*  
052 189 47 /SNA

H	B	L heat exchanger	L 189	209	229	249	269	289	309	329
52	47	75/65/20 90/70/20	2265 2903	2567 3291	2869 3678	3171 4065	3473 4452	3775 4839	4077 5226	4379 5613

Rigid grille in natural coloured anodized aluminium. Frame in black anodized aluminium.  
Free air flow 75%.

Deliverable with frame in natural coloured aluminium, or with other grilles (see page 230): for this put the unit together from parts.

Caution: extended delivery time!

## Roll-up grilles

### Merbau or oak\_natural



ORDERING CODE: CC40. *code* *height* *length* *width* *grille*  
052 189 47 /RMN  
/RON

H	B	L heat exchanger	L 189	209	229	249	269	289	309	329
52	47	75/65/20 90/70/20	2197 2816	2490 3192	2783 3567	3076 3943	3369 4319	3662 4694	3955 5070	4248 5445

Roll-up grille in merbau or oak natural, with dark brown coloured synthetic distance pieces. Frame in black anodized aluminium.  
Free air flow 63%.

